

## STEP 9 Tail Transmission Output Gear

From parts bag 2: Assemble the Tail Transmission Output Gear assembly. Install the E-Ring (be careful not to lose it, it can easily spring away during installation). Slide the two Ball Bearings onto the front of the Tail Rotor Output Shaft. Using threadlock, insert one 3x4mm Set Screw into the gear, Note where the flat spot is on the shaft, slide the gear on and tighten the set screw (**Make sure the set screw is positioned over the flat spot**).

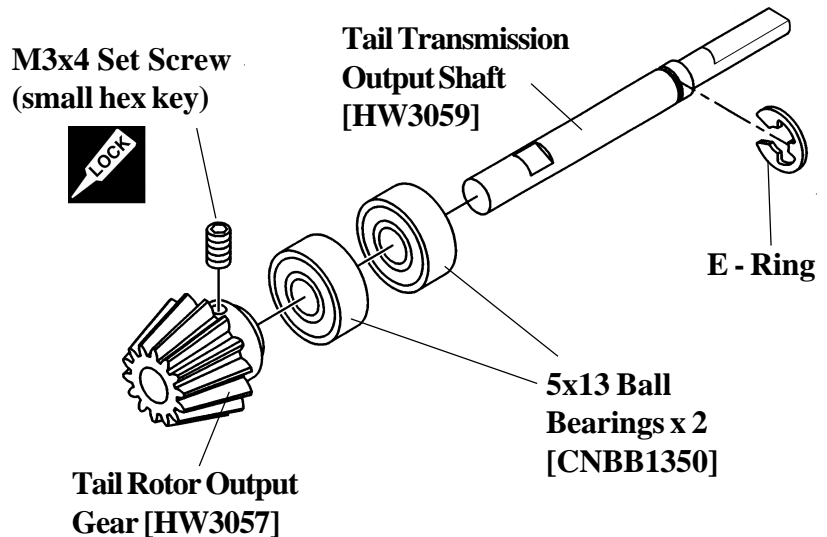

## STEP 10 Counter Gear Assembly

From parts bag 2: Assemble the engine drive gear assembly. Start by inserting the guide pin into the hole in the end of the Drive Shaft. Insert the shaft through the Counter Gear (make sure the pin is fully seated in the recessed slot at the bottom of the gear) then slide the two M5x13 Ball Bearings followed by the two M5x7 spacers. Using locktite, insert one 3x4mm Set Screw into the Alloy Drive Gear, then slide the gear onto the shaft taking care to position the set screw over the flat spot on the shaft. Secure the drive gear to the shaft.

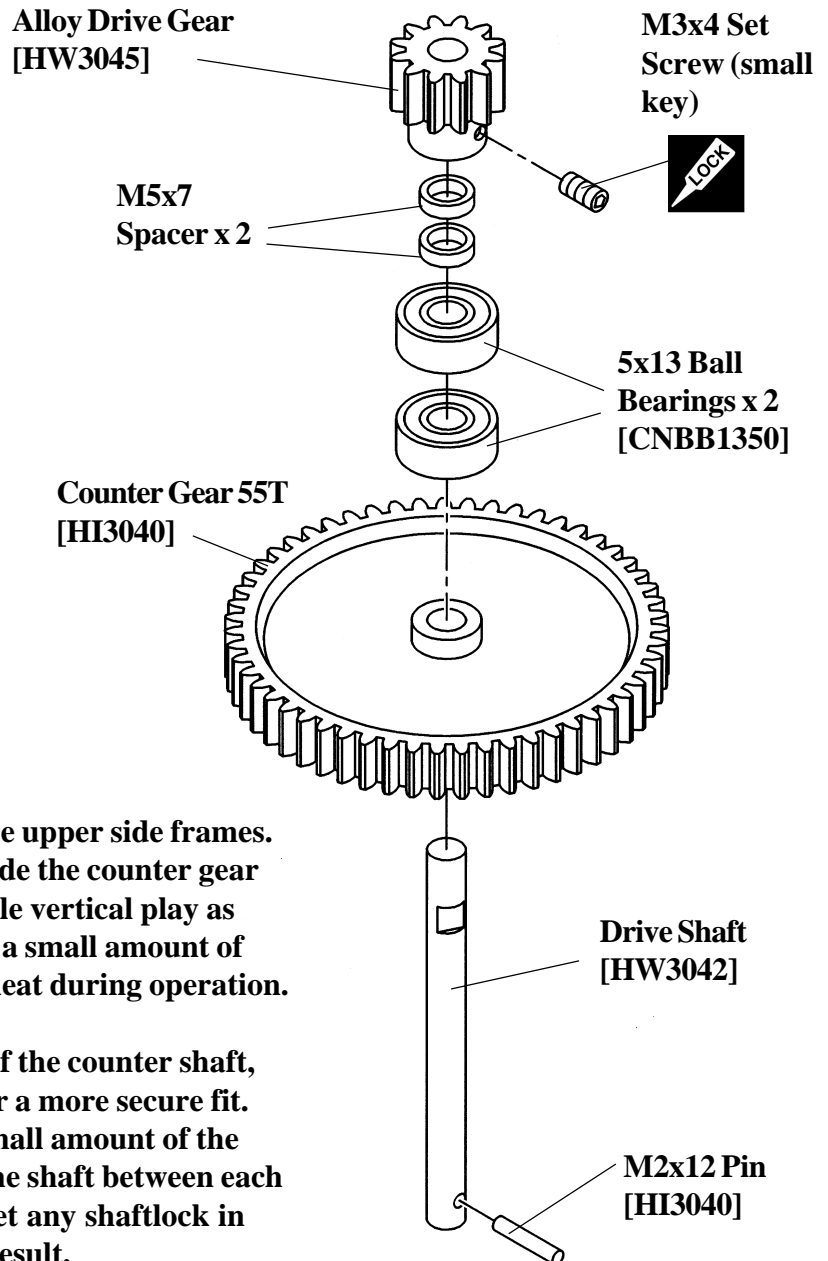

**!** Careful setup in the drive train will ensure trouble free operation.

Test fit the gear assembly into one half of the upper side frames. While holding the alloy drive gear, try to slide the counter gear up and down on the shaft. Adjust for as little vertical play as possible. It is normal and necessary to have a small amount of vertical play to allow for expansion due to heat during operation.

A small amount of red locktight to the top of the counter shaft, between it and the pinion gear will make for a more secure fit. Only use blue locktite on the set screw. A small amount of the blue locktite can be applied carefully on the shaft between each bearing and the shaft. **Warning**, do not get any shaftlock in the bearing as damage to the bearing may result.