

STEP 3 Main Blade Grip Assembly

! Note, the long ball is installed pointing away from the blade grip.

From parts bag 1: Install one Long Ball and one Short Ball into the Bell Mixer, insert the slide tube into the bell mixer arm (**Note: the oilite bearings are pre-installed**) and secure onto the blade grip with one M3x16 Socket Cap screw and M3x7 Flat washer. Install two M5x13 Ball Bearings into each end of the blade grip assembly. Complete the second blade grip in exactly the same way.

Optional SE Ball Bearing Set replaces the two oilite bushings

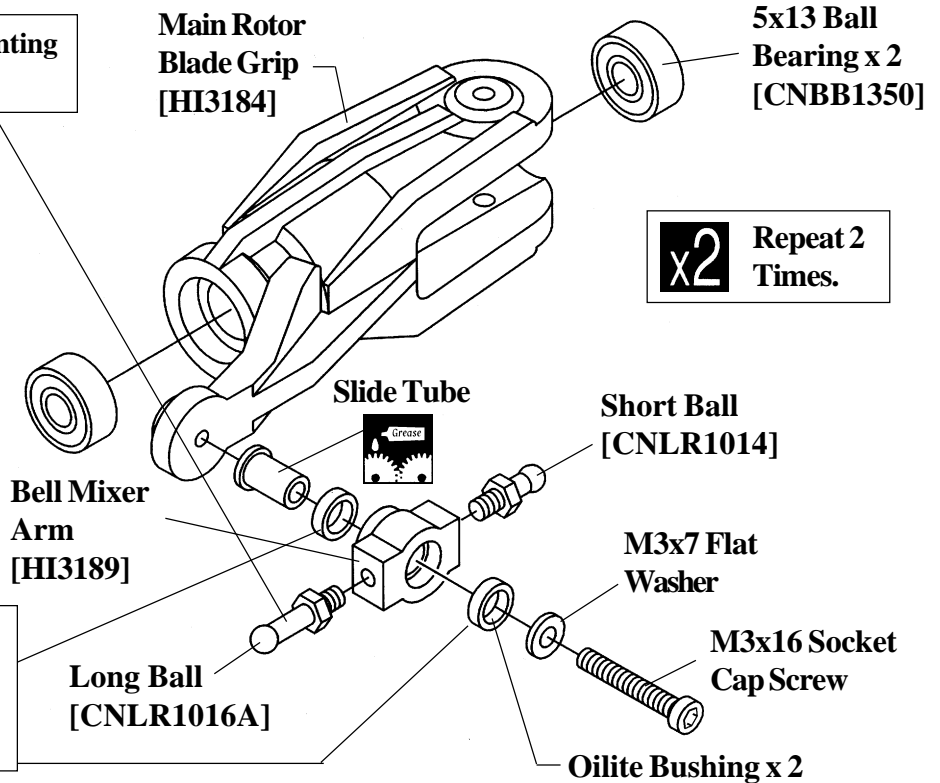

! Top of blade grip has Bevel.

STEP 4 Feathering Spindle & Blade Grips

From parts bag 1: Insert the Feathering Shaft into the head block, slide one 5X10mm Washer on each side of the shaft. Install the blade grip (**Note the direction of the bell mixer arm with the beveled edge on top of the blade grip**) followed by one 4x10mm Washer, one 4x12mm Washer and one 4mm Locknut. Assemble Pushrod "I" x 2, measuring 28mm center to center distance following the table on page 25, and connect the seesaw ball to the long ball on the bell mixer.

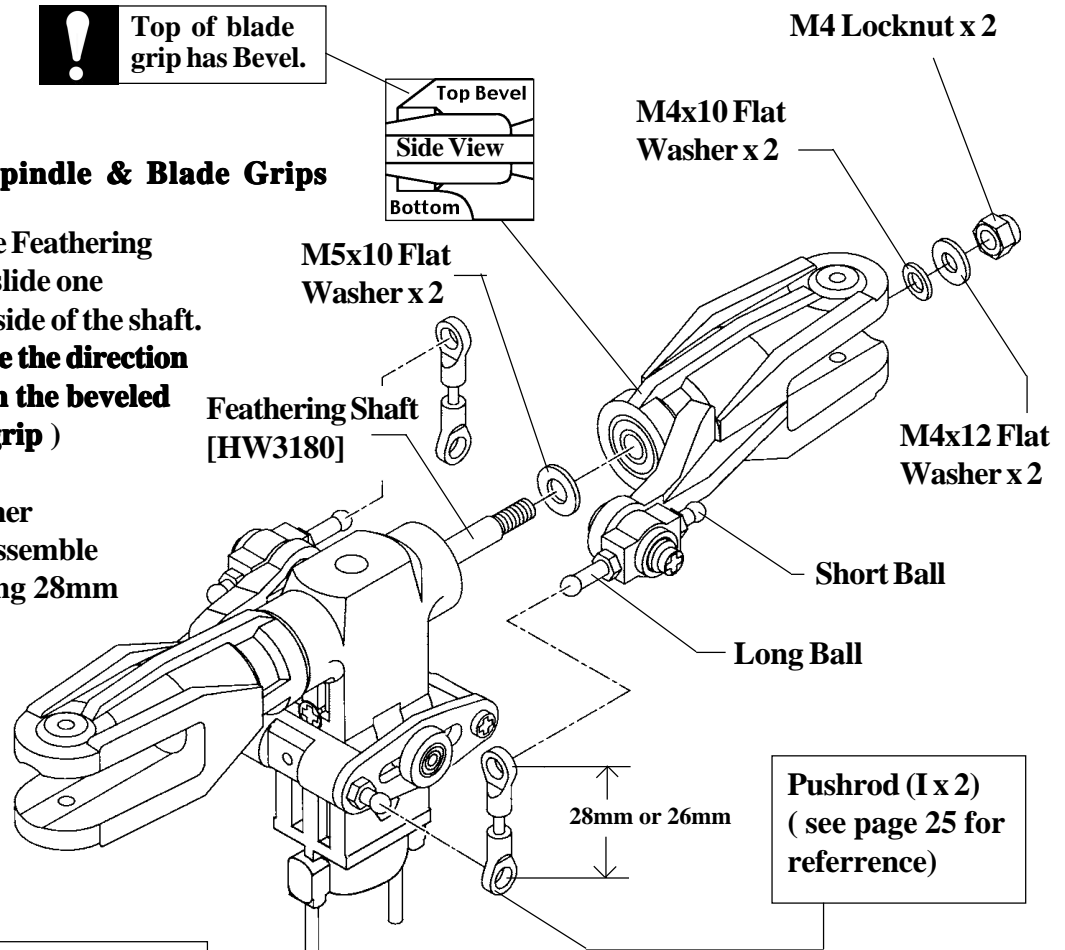

! Pushrod "I" will require a 26mm length for a 3D setup - see page 25.