

Pitch Curve

Hovering - (linear) Normal Flight Mode

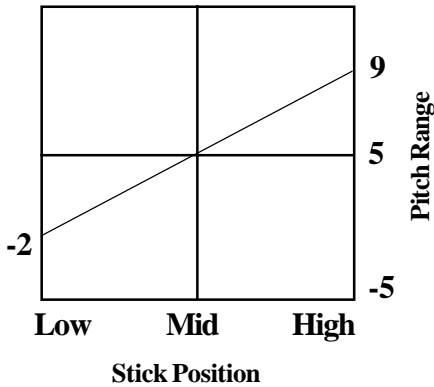

Aerobatic Flying - Flight Mode 1

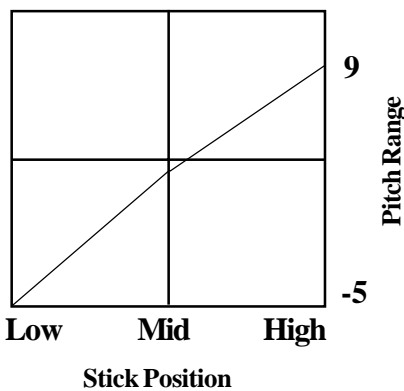

3D Flying - Flight Mode 2

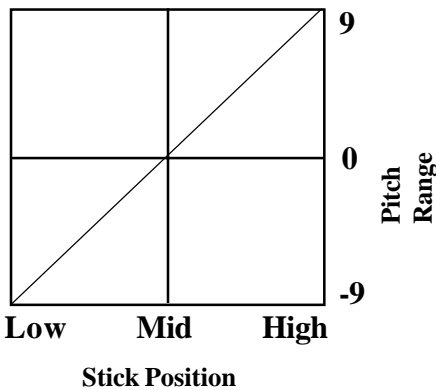

Autorotation - Throttle Hold

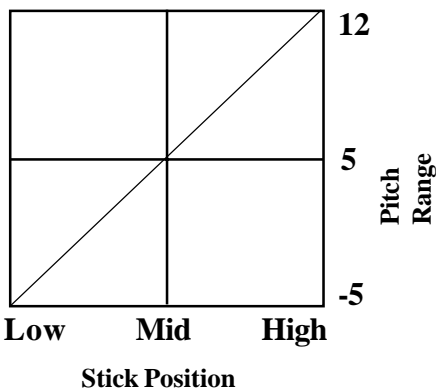

Using Pitch & Flybar Paddle Gauge CN2026 (Purchased Separately)

Before making accurate pitch readings or aligning paddles, the helicopter should have all linkages attached at the factory normal settings with the servos connected, working and moveable to the endpoints of the servo without binding. Also have the swashplate set level in the fore/aft and left/right directions. Turn the radio on and take different readings at the different throttle/collective stick positions.

Pitch Gauge

1. Loosen the thumb screw on the back side of the gauge, open the jaws and position the gauge on the blade near the rotor head, see photo#2.
2. Position the flybar perpendicular (90°) to the main shaft.
3. Take 3 readings: at low pitch, at hover pitch and high pitch.
4. To read the blade pitch, while looking at the gauge in photo#2, align the bottom or top by sighting the edge of the gauge parallel to the flybar. When these are parallel, read the value at the pointer on the scale.
5. Repeat this process for the opposite blade, make changes in the radio or in the length of pushrod C if necessary.

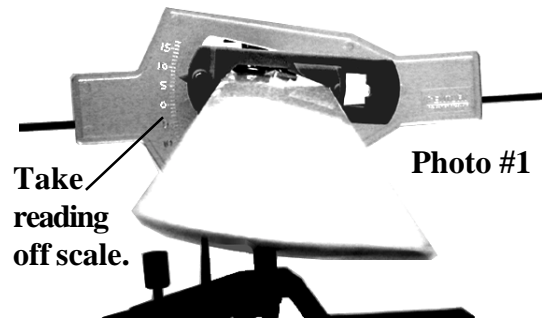

Take reading off scale.

Photo #1

Sighting Edges A or B



Photo #2

Flybar Paddle Alignment Gauge

1. Make sure the flybar is centered in the rotor head using a ruler. Install the flybar control arms and paddles on each side. Leave the set screws on the control arms slightly loose so they rotate but do not slide.
2. Disassemble the center part of the pitch gauge and slide one paddle gauge on each flybar paddle. Adjust the paddles until both gauges are parallel to each other, as in photo#3.
3. Make sure the swashplate is level, align the paddles to the flybar control arms and tighten the set screws.

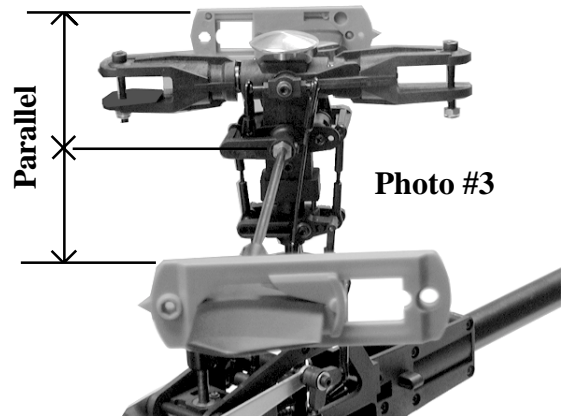

Photo #3