

STEP 31 Tail Rotor Hub

From parts bag 7: Install the Tail Rotor Hub onto the tail rotor output shaft (position the hub so the hole is aligned over the indent hole on the shaft) and secure with one M3x4 set screw using threadlock. Insert one M3x10 Socket Cap Screw through one M3x10 Ball Bearing (apply the threadlock to the inside threads of the hub) and into the tail rotor hub. Repeat for the other side.

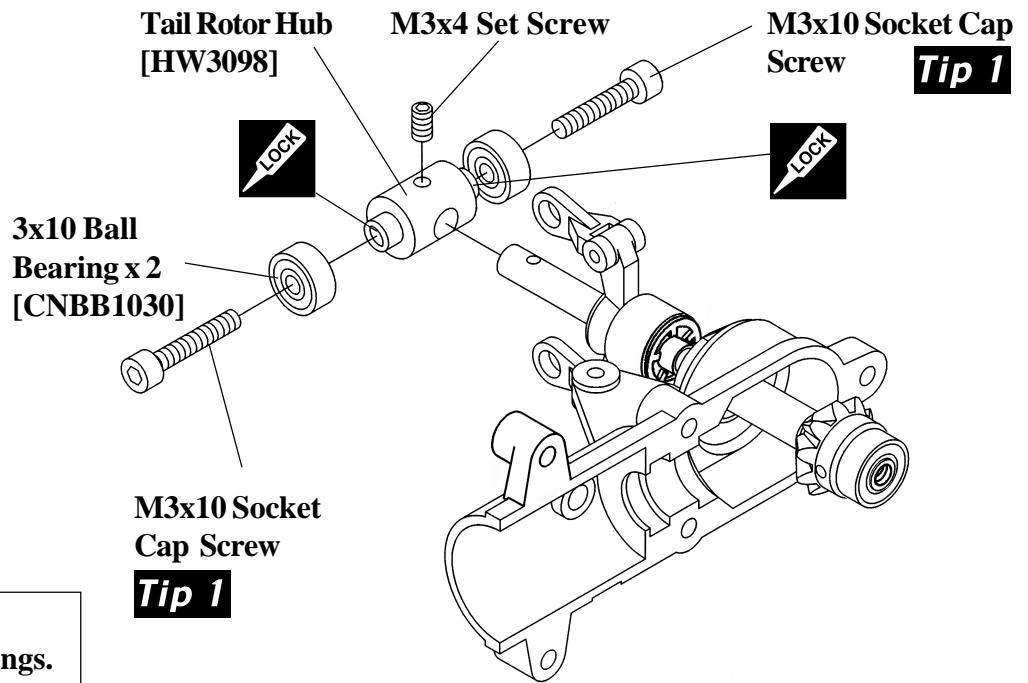

Avoid getting any threadlock in the bearings.

STEP 32 Tail Rotor Grips & Tail Rotor Pitch Lever

From parts bag 7: Using threadlock on the two M2x10 Phillips Machine Screws and 2mm Nuts, assemble both Blade Grip Halves over the bearings with the nuts facing to the gearbox, Snap the two balls from the tail rotor grip into the adjoining pitch slider links. Install the Tail Rotor Blades using two M3x16 Socket Cap Screws and M3 locknuts. Note the direction of the blades on the diagram, the straight leading edge of the blade should be on the same side as the ball on the blade grip.

Install the M2 Short Steel Ball, threaded from the bottom of the bellcrank. Install the tail rotor bellcrank onto the tail rotor gear box with one M3x16 Socket Cap Screw, inserted through the brass bushing with the washer side on the bottom (**make sure the steel ball at the bottom of the pitch slider is engaged into the end of the t/r bellcrank**) and thread into the hole on the tail rotor gearbox.

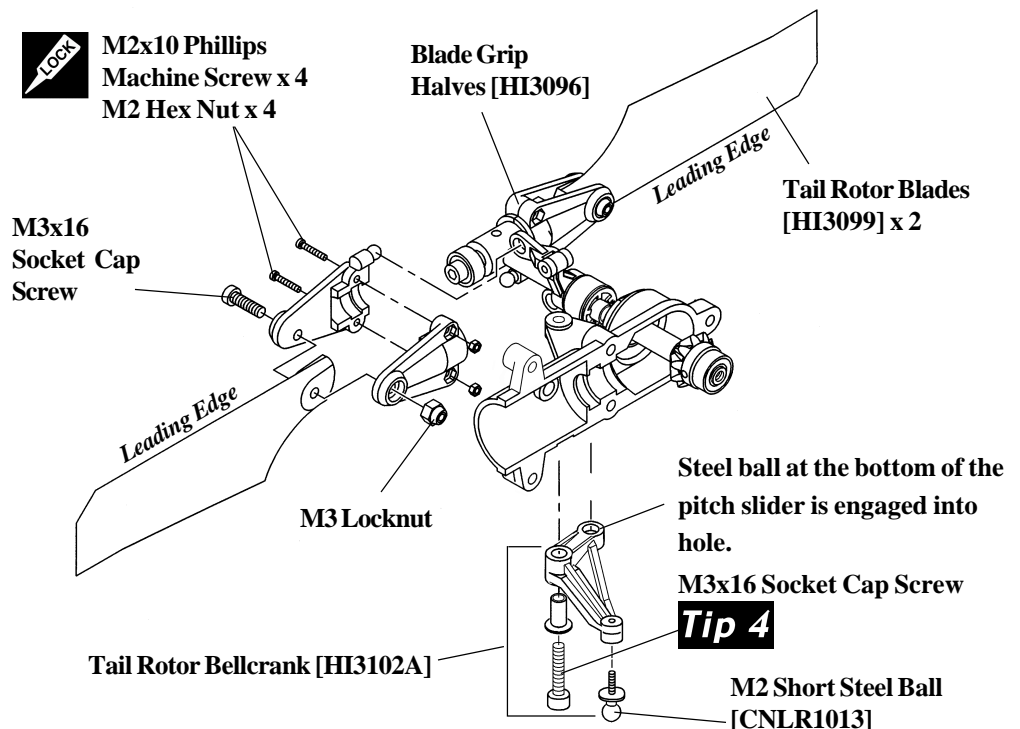

After flying the model, if a buzzing vibration is noticed on the ends of the vertical or horizontal fin, you can remove the complete tail rotor assembly with the hub and further balance it using a High Point balancer. Careful sanding of the rotor blades is all that would be needed.