

STEP 28 Tail Pitch Plate

From parts bag 7: The Tail Pitch Plate and Tail Pitch Ball Links are pre-assembled. (Note: apply some JB weld to the outside of the lock ring to avoid the assembly loosening. Apply CA type glue to bond the brass slide tube to the pitch plate.) Put this assembly aside for later.

Tail Pitch Ball Links x 2
M2x8 Pin x 2
[HI3089]

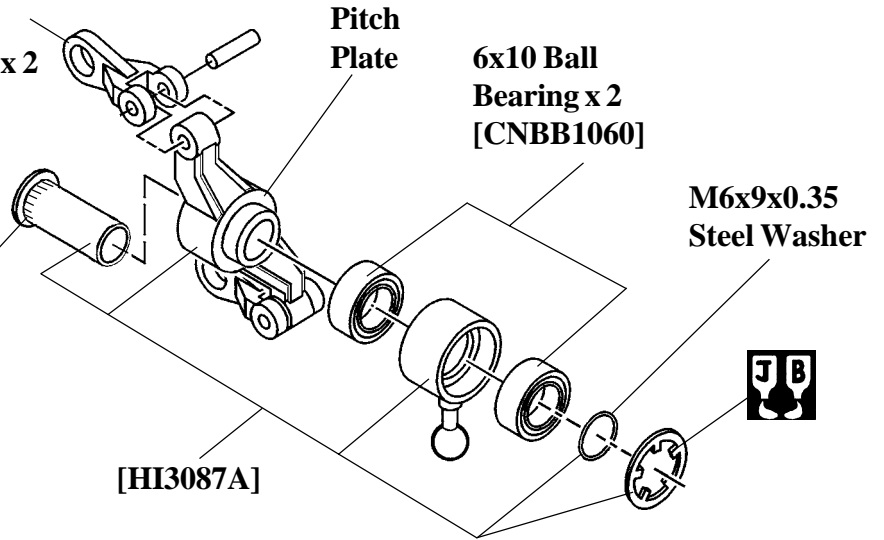

Warning, do not get any glue in the bearings.

STEP 29 Tail Gearbox Input Shaft

From parts bag 7: Assemble the Tail Rotor Output Shaft assembly by sliding the two M13x5 Ball Bearings on to the shaft, followed by the **LARGE** Bevel Gear with the teeth facing outwards. Align the holes in the gear with the shaft and press in the M2x12 pin. Using threadlock, secure with one M3x4 Set Screw.

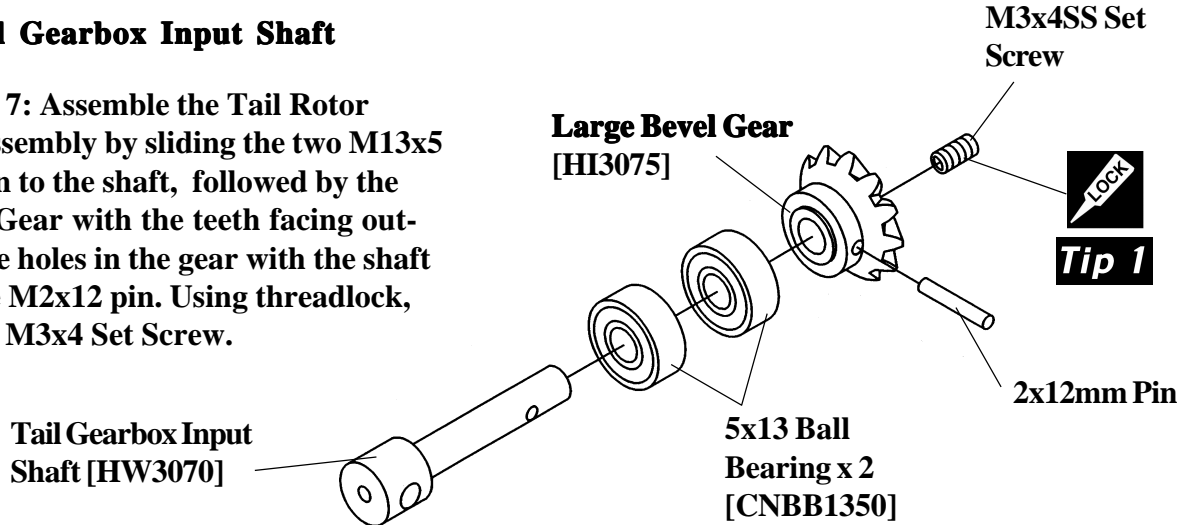

STEP 30 Tail Output Shaft Assembly

Slide one of the two M11x5 Ball Bearings onto each end of the Tail Rotor Drive Shaft assembly and insert through the inside of the right side of the Tail Rotor Gearbox Housing. Make sure the bearing is fully seated into the recess. Slide the tail rotor pitch plate assembly onto the shaft.

